

H663 Series

Split-Core Branch Current Monitor



Installer's Specifications

General:

Operating temp. range	0° to 60°C (<95%RH, non-condensing)
Storage temp. range	-40°C to 70°C
Control (Mains) Power Source	120 VAC L-N, 50/60 Hz (208/230 VAC for H663SM-xxE) (+10/-25%)
Primary Fusing	250 VAC/100 mA, (T) 5 x 20 mm, Littelfuse 218 series or equivalent
Altitude of Operation	3 km max.

Measured Current Inputs:

Number of Channels available	42, 30, 24, 12, or 1
Frequency	50/60 Hz
Sample Frequency	1280 Hz
Update Rate	1.2 sec
Accuracy	±5% from 5 A to 50 A 10 A to 100 A (H663SM-42H only)

Connection to Conductor	Inductive split-core CT
Measured Currents	Current range 0-50 A or 0-100 A (H663SM-42H)

Network Communications:

Type	Modbus RTU
Connection	DIP switch-selectable 2-wire or 4-wire
Address	DIP switch-selectable address 1 to 247
Baud Rate	DIP switch-selectable 2400, 4800, 9600, 19200
Parity	DIP switch-selectable NONE, ODD, EVEN
Communication Format	8-data-bits, 1-start-bit, 1-stop-bit
Termination	5-position depluggable connector

Defaults:

Warning Register	60% of current sensor max. (configurable)
Alarm Register	70% of current sensor max. (configurable)
Breaker Size Register	20 A

The complete product series designation is H663-XX(H)(E). The "XX" refers to the number of CTs included with the device.

QUICK INSTALL

1. Disconnect and lock out power.
2. Snap split-core CT's onto branch circuit wires.
3. Connect power leads and CT's to the board terminals.
4. Mount board onto electrical enclosure.
5. Connect CT's and wire the board.
6. Reconnect power.
7. Configure communication and addressing parameters.



DANGER

HAZARD OF ELECTRIC SHOCK, EXPLOSION, OR ARC FLASH

- Follow safe electrical work practices. See NFPA 70E in the USA, or applicable local codes.
- This equipment must only be installed and serviced by qualified electrical personnel.
- Read, understand and follow the instructions before installing this product.
- Turn off all power supplying equipment before working on or inside the equipment.
- Use a properly rated voltage sensing device to confirm power is off.
DO NOT DEPEND ON THIS PRODUCT FOR VOLTAGE INDICATION
- Only install this product on insulated conductors.

Failure to follow these instructions will result in death or serious injury.

NOTICE

- This product is not intended for life or safety applications.
- Do not install this product in hazardous or classified locations.
- The installer is responsible for conformance to all applicable codes.

FCC PART 15 INFORMATION

NOTE: This equipment has been tested by the manufacturer and found to comply with the limits for a class A digital device, pursuant to part 15 of the FCC Rules. These limits are designed to provide reasonable protection against harmful interference when the equipment is operated in a commercial environment. This equipment generates, uses, and can radiate radio frequency energy and, if not installed and used in accordance with the instruction manual, may cause harmful interference to radio communications. Operation of this equipment in a residential area is likely to cause harmful interference in which case the user will be required to correct the interference at his own expense. Modifications to this product without the express authorization of Veris Industries nullify this statement.

ORDERING INFORMATION

MODEL	# of CT's
H663SM-xx(H)(E)	xx = 40, 30, 24, 12, or 1 (selectable)

For 240VAC version, order the H663SM-xxE.
 For the 100A CT version, order the H663SM-xxH.
 For the 240V, 100A version, order the H663SM-xxHE.

OPERATION

Designed for critical load monitoring such as co-location data centers and lighting panels, the H663 series monitors current on up to 42 branch circuits in a 120/208/230 VAC electrical panel. By individually reporting current draw and initiating capacity warnings and alarms, the H663 series allows the user to manage load and eliminate power disturbances caused by overloaded breakers.

The H663 series consists of a data acquisition system board and up to 42 individual split-core current transformers (CTs). The acquisition board should be mounted inside the electrical panel or in an enclosure mounted near enough for the CT output leads to reach the acquisition board connectors. The CTs are clipped onto each of the branch circuit conductors. These CTs transmit amperage data from each monitored circuit to the acquisition system for processing.

Current and alarm information is transmitted to the user's Control Data Acquisition system over an RS485 drop using the Modbus protocol.

Set-up is made easy with a PC based configuration tool which allows for global or individual selection of breaker size, warning levels, and alarm levels.

DIMENSIONS

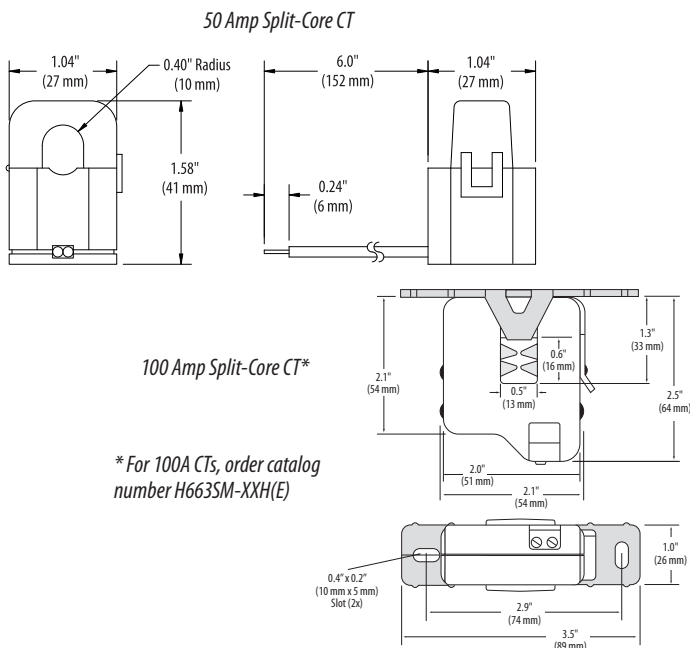
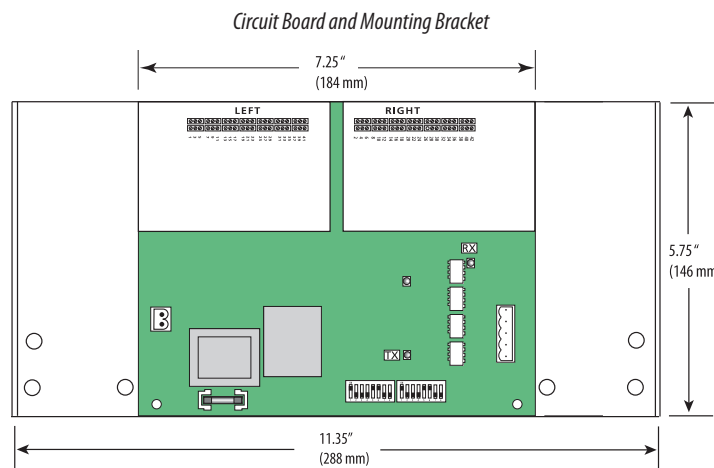

PRODUCT DIAGRAM

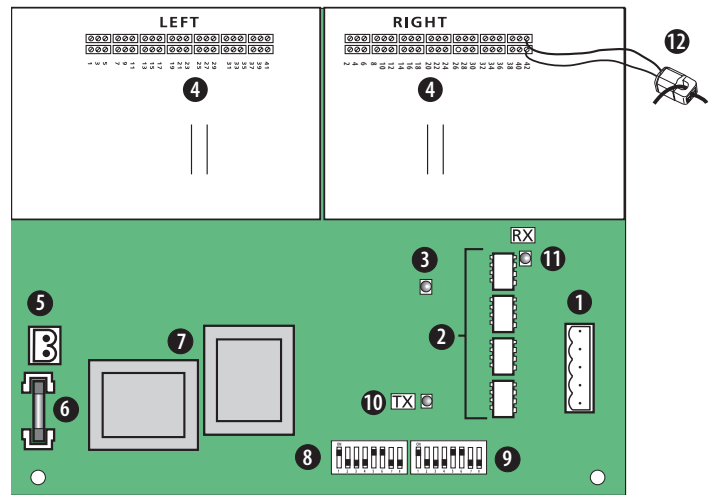

- RS 485 2 or 4-Wire Connection:** Daisy chain multiple H663's using a 2-wire or 4-wire modbus network.
- Optical Communications Isolation:** Optical isolators are used to separate 120 VAC portions of the circuit from the RS485 network.
- Alive LED:** Flashes once per second to indicate correct operation. If steadily lit or out, indicates internal failure.
- Current Transformer (CT) Connectors (Interconnection Boards):** Numbered terminals correspond to the input channels of the acquisition board. Fasten the current transformer connectors into the terminals as shown in the Wiring section of this guide.
- Control (Mains) Power Connection*:** Easy 2-wire 120 VAC line to neutral 50/60 Hz.
- 250VAC 100mA Time Delay Fuse:** Fused power connection for circuit protection.
- Power Transformers:** Linear power supply for reliability and low noise
- Baud Rate & Parity Selection Switches:** Field selectable RS-485 serial interface control.
- Modbus Address Dip Switches:** Each Modbus device must have a unique address. These switches must be set to assign an individual address before the device is connected to the network.
- TX LED:** Indicates transmission of information over the Modbus network.
- RX LED:** Indicates data received on the Modbus network
- Current Sensors:** Each current sensor is capable of monitoring conductors carrying up to a maximum of 50 amps. The H663SM-42H is capable of monitoring conductors up to a maximum of 100 amps.

*For 208/230VAC Power Connection version, order catalog number H663SM-xxE.

SAFETY

UL listed under standard 508 as an "open type device."

Installation category: CAT II or CAT III

Critical components evaluated to UL 1950.

The H663 Series must be installed in as appropriate electrical and fire enclosure per local regulations.

For use in a Pollution Degree 2 or better environment only.

A Pollution Degree 2 environment must control conductive pollution and the possibility of condensation or high humidity. Consideration must be given to the enclosure, the correct use of ventilation, thermal properties of the equipment and the relationship with the environment.



This symbol indicates an electrical shock hazard exists.



Documentation must be consulted where this symbol is used on the product.

INSTALLATION

1. Inspect the Mounting Bracket Kit. The acquisition and interconnection boards are mounted to the bracket at the factory.

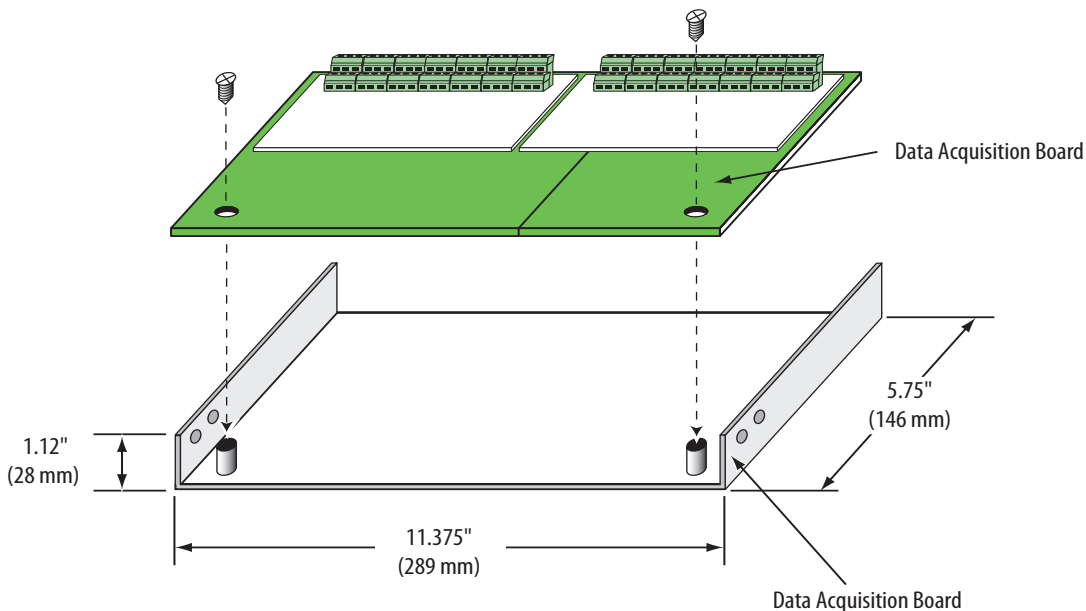

INSTALLATION, CONT.

2. Assure power to the electrical panel is OFF and locked out. 
3. Snap split-core CT's on branch circuit wires. (CT's may need to be staggered).
4. Prepare 120VAC* 50/60Hz power leads and connect to line and neutral terminals of the acquisition board. Allow wiring length to fit when board is installed. **DO NOT CONNECT LINE VOLTAGE UNTIL LAST STEP!**
5. Connect current transformers to interconnection board terminals.

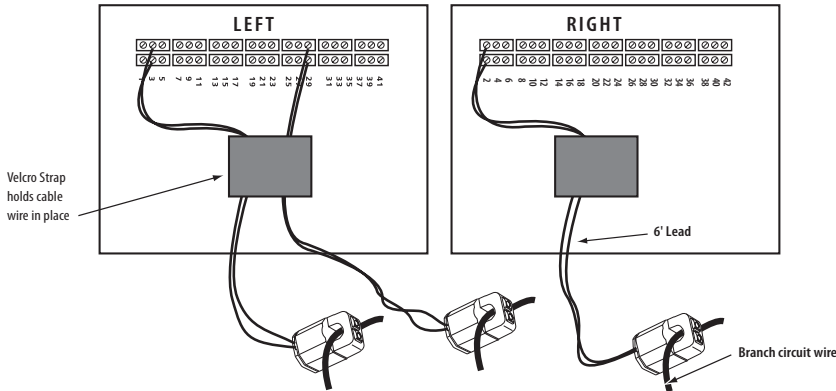

6. Acquisition Board Installation: Find screw holes under panel board in side of chassis or panel. Attach Data Acquisition Board.

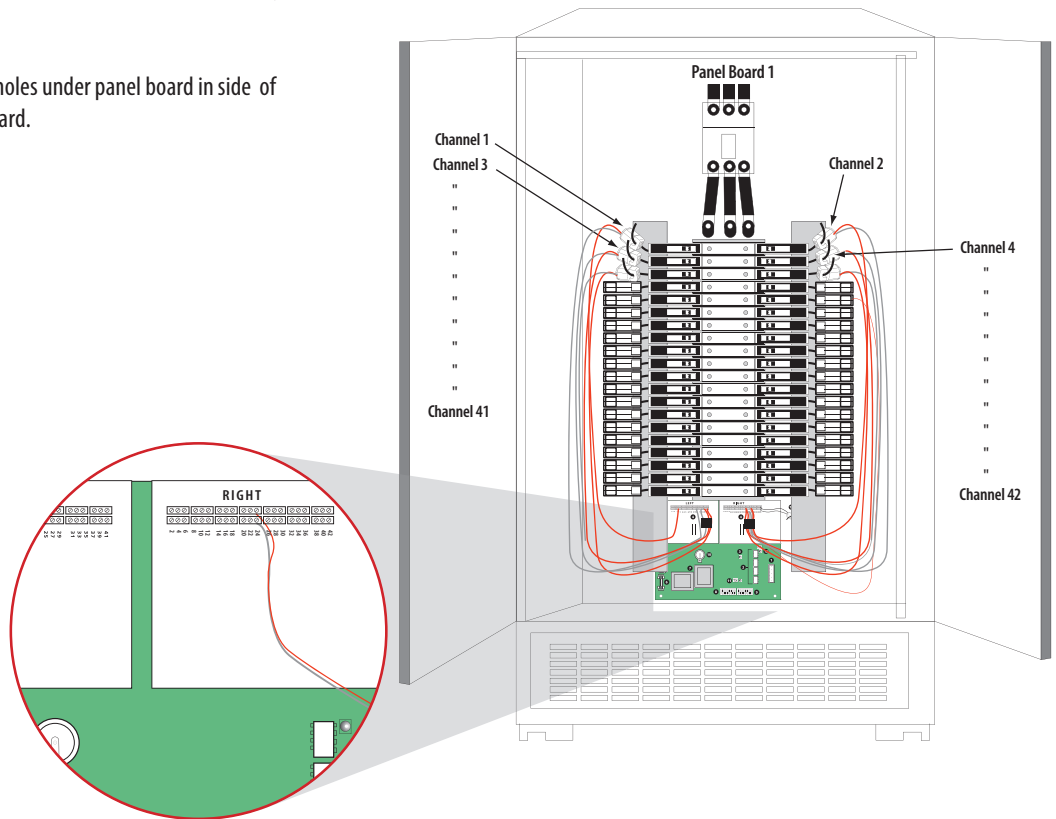

DANGER: Beware of exposed busbars on back of panelboard when installing circuit board assembly/mounting bracket. Assure adequate clearance between live parts and this product.

* 208/230VAC for H663SM-xxE

WIRING

Power must be disconnected and locked out before making any wiring connections.

1. Connect 2-wire or 4-wire Modbus RS485 network.

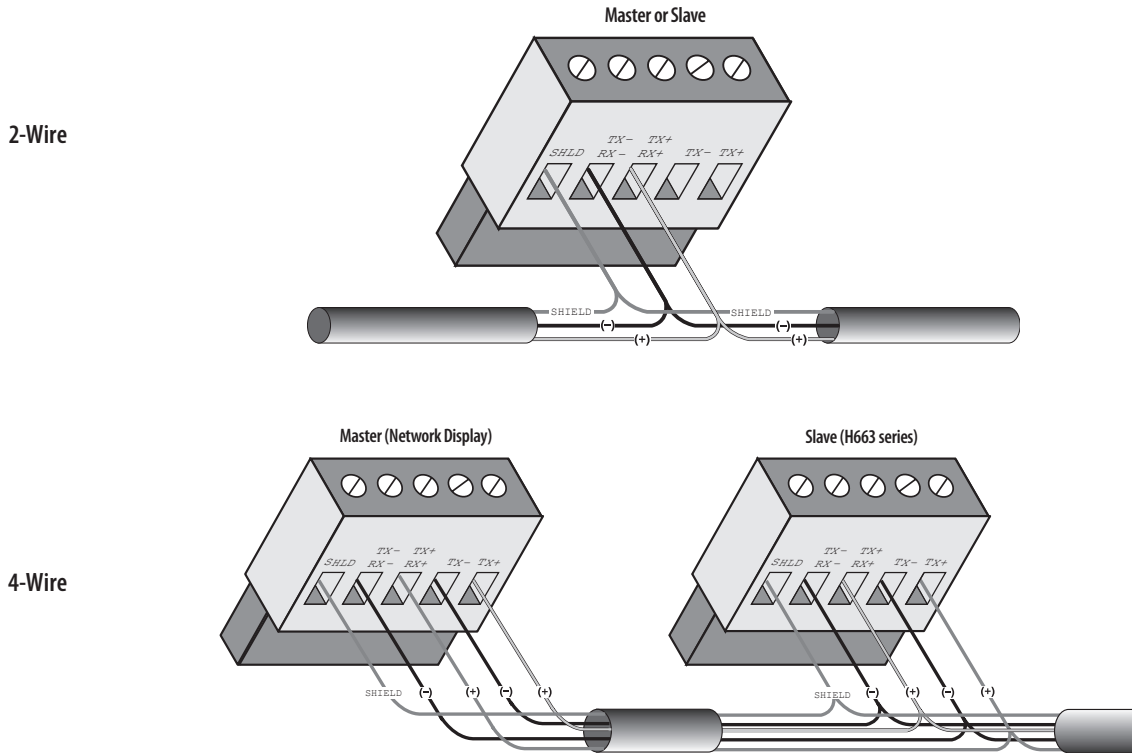

NOTES

- A. The Modbus cable should be mechanically secured where it enters the electrical panel.
- B. All Modbus devices should be connected together in a daisy-chain fashion, and properly terminated.
- C. The Modbus cable should be shielded twisted pair wire such as Belden 1120A. The cable must be voltage rated for the installation.

 **WARNING:** After wiring the Modbus cable, remove all scraps of wire or foil shield from the electrical panel. This could be DANGEROUS if wire scraps come into contact with high voltage conductors!

2. Use the Software Configuration Tool to set up breaker size, warning levels, and alarm levels. This tool is available online at <http://www.veris.com/modbus.asp>
3. Connect power.

 Disconnect and lock out power source before making any connections. Connect 2-wire 120 VAC power to power terminals. See Product Diagram section for location. **Observe polarity.**

CONFIGURATION

1. **Communications Configuration:** Communications parameters for the H663 series are field selectable for your convenience. Please see Product Diagram section for selector location. The following parameters are configurable:

- Parity: Odd, even or none
- Wiring: Two or four
- Baud Rate: 2400, 4800, 9600 or 19200



Example: 2-wire 9600 Baud No Parity (Default Only)

Baud Rate and Parity Switch Settings

Switch #								Wiring, Baud Rate, Parity		
1	2	3	4	5	6	7	8	Wiring	DESIRED RESULT Baud Rate	Parity
X	On					X	X	2 wire		
X	Off					X	X	4 wire		
X		Off	Off			X	X		2400 Baud	
X		On	Off			X	X		4800 Baud	
X		Off	On			X	X		9600 Baud	
X		On	On			X	X		19200 Baud	
				Off	Off					None
				On	Off					Even
				Off	On					Odd

2. **Address Configuration:** Each ModBus device on a single network must have a unique address. The switch block must be set to assign a unique address before the device is connected to the ModBus RS485 network. If an address is selected which conflicts with another device, neither device will be able to communicate.

H663 series can be addressed as any whole number between and including 1-247. Each unit is equipped with a set of 8 dip switches for addressing.



DIP SWITCH

VALUES: 1 2 4 8 16 32 64 128

To determine an address you simply add the values of any switch that is on.

For example:

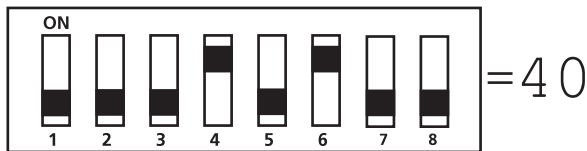

Switch number 4 has an ON Value of 8 and switch number 6 has an ON Value of 32. (8+32 = 40).

See the Communications Setup section for a pictorial listing of the first 63 switch positions.

COMMUNICATIONS SETUP



DO NOT USE ZERO

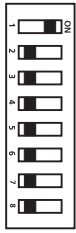

1

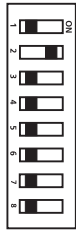

2

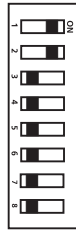

3

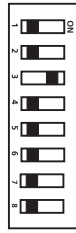

4

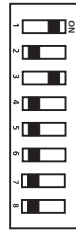

5



6



7

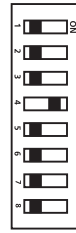

8

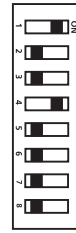

9



10

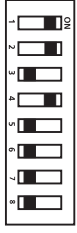

11

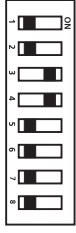

12

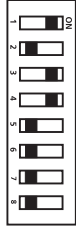

13

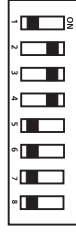

14

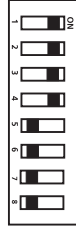

15



16



17



18



19

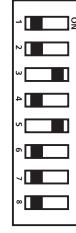

20

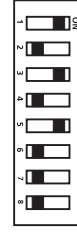

21

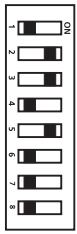

22

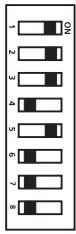

23

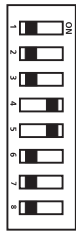

24

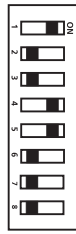

25

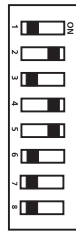

26

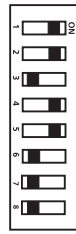

27



28

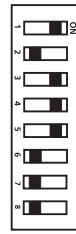

29

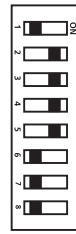

30



31

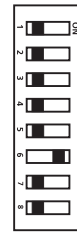

32

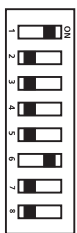

33

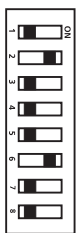

34

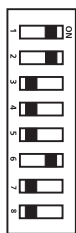

35

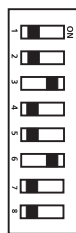

36



37



38



39

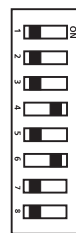

40

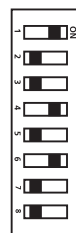

41



42



43

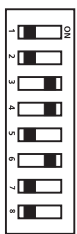

44

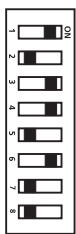

45

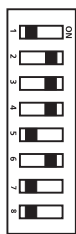

46

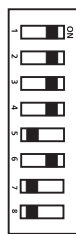

47

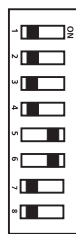

48

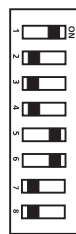

49

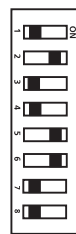

50



51



52



53



54

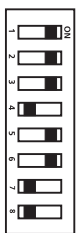

55

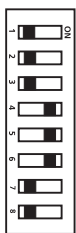

56



57



58

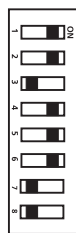

59



60



61



62



63

SERVICE

Changing the Fuse

1. Disconnect and lock out power to panel.
2. Disconnect and lock out 120V* Control (Mains) Power Source to Data Acquisition Board.
3. Remove old fuse.
4. Replace with new fuse, Littlefuse 218 series or equivalent.
5. Reconnect 120V** to Data Acquisition Board.
6. Reconnect power to panel.
7. Check "Alive" LED for proper function (See Product Diagram section for location).

**208/230VAC for H663SM-xxE*

***If fuse blows repeatedly, check power source to ensure that it is a stable 120VAC source.*