

ENERCEPT® H8035/H8036

Modbus Energy Meter Networked kW/kWh Transducers



US Patent No. 6,373,238



Installer's Specifications

Input Voltage	208 to 480 VAC
Number of Phases Monitored	1 or 3
Frequency	50/60 Hz
Maximum Primary Current	100/300/400/800/1600/2400 A continuous per phase
CT case isolation	600 VAC
Internal isolation	2000 VAC rms
Operating temp. range	0° to 60°C (32° to 122°F) (<95%RH, non-condensing)
Storage temp. range	-40° to 70°C (-40° to 158°F)
Accuracy	±1% of reading from 10% to 100% of the rated current*
Output Type	RS-485, 2-wire plus common
Baud Rate	9600
Protocol	Modbus RTU

* Meter accuracy specified with conductors centered in the CT window.

DANGER

HAZARD OF ELECTRIC SHOCK, EXPLOSION, OR ARC FLASH

- Follow safe electrical work practices. See NFPA 70E in the USA, or applicable local codes.
- This equipment must only be installed and serviced by qualified electrical personnel.
- Read, understand and follow the instructions before installing this product.
- Turn off all power supplying equipment before working on or inside the equipment.
- Use a properly rated voltage sensing device to confirm power is off.
- **DO NOT DEPEND ON THIS PRODUCT FOR VOLTAGE INDICATION**
- Only install this product on insulated conductors.

Failure to follow these instructions will result in death or serious injury.

NOTICE

- This product is not intended for life or safety applications.
- Do not install this product in hazardous or classified locations.
- The installer is responsible for conformance to all applicable codes.
- Mount this product inside a suitable fire and electrical enclosure.

QUICK INSTALL

Disconnect and lock out power before installation.

1. Set the address switches located on the bottom of the CT.
2. Connect the voltage leads to the source to be monitored.
3. Snap the CT onto the conductor (observe color matching).
4. Connect the Modbus wires (observe polarity).

FCC PART 15 INFORMATION

NOTE: This equipment has been tested by the manufacturer and found to comply with the limits for a class A digital device, pursuant to part 15 of the FCC Rules. These limits are designed to provide reasonable protection against harmful interference when the equipment is operated in a commercial environment. This equipment generates, uses, and can radiate radio frequency energy and, if not installed and used in accordance with the instruction manual, may cause harmful interference to radio communications. Operation of this equipment in a residential area is likely to cause harmful interference in which case the user will be required to correct the interference at his own expense. Modifications to this product without the express authorization of Veris Industries nullify this statement.

PRODUCT IDENTIFICATION

*Modbus Enhanced Data Stream Meters**

MODEL	MAX. AMPS	CT SIZE
H8036-0100-2	100	SMALL
H8036-0300-2	300	SMALL
H8036-0400-3	400	MEDIUM
H8036-0800-3	800	MEDIUM
H8036-0800-4	800	LARGE
H8036-1600-4	1600	LARGE
H8036-2400-4	2400	LARGE

*H8036 models work with H8920-1 LON nodes

*Modbus Basic Energy Meters**

MODEL	MAX. AMPS	CT SIZE
H8035-0100-2	100	SMALL
H8035-0300-2	300	SMALL
H8035-0400-3	400	MEDIUM
H8035-0800-3	800	MEDIUM
H8035-0800-4	800	LARGE
H8035-1600-4	1600	LARGE
H8035-2400-4	2400	LARGE

*H8035 models work with H8920-5 LON nodes

DIMENSIONS

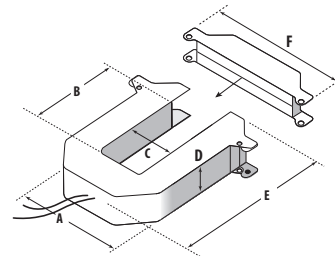

**SMALL
100/300 Amp**

- A = 3.8" (96 mm)
- B = 1.2" (30 mm)
- C = 1.3" (31 mm)
- D = 1.2" (30 mm)
- E = 4.0" (100 mm)
- F = 4.8" (121 mm)

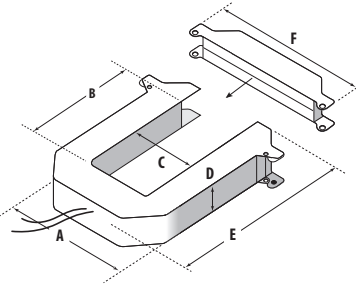

**MEDIUM
400/800 Amp**

- A = 4.9" (125 mm)
- B = 2.9" (73 mm)
- C = 2.5" (62 mm)
- D = 1.2" (30 mm)
- E = 5.2" (132 mm)
- F = 5.9" (151 mm)

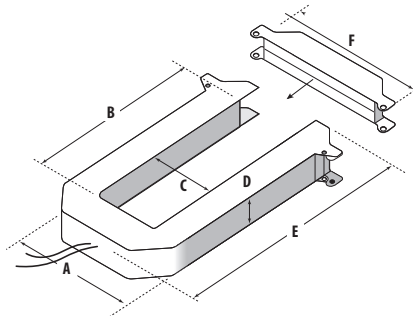

**LARGE
800/1600/2400 Amp**

- A = 4.9" (125 mm)
- B = 5.5" (139 mm)
- C = 2.5" (62 mm)
- D = 1.2" (30 mm)
- E = 7.9" (201 mm)
- F = 6.0" (151 mm)

OPERATION

The H8035 and H8036 three-phase power transducers monitor energy parameters from aggregate kW (real power) and kWh (consumption) to power factor per phase. Integration of electronics lowers hardware and installation costs. The sensors automatically detect phase reversal, so CT load orientation is not a concern. The CTs and meters are calibrated as a set, so it is necessary to color-match the CTs and voltage leads when installing. These devices monitor up to 63 loads at a time on a single RS-485 drop.

With two platforms to choose from (H8035 Energy Only or H8036 Enhanced Data Stream), the applications for these devices are diverse, including aggregate billing, tenant submetering, energy management, performance contracting, demand limiting and cooling plant optimization. The 1% total system accuracy conforms to ANSIC12.1 metering standards.

PRODUCT DIAGRAM

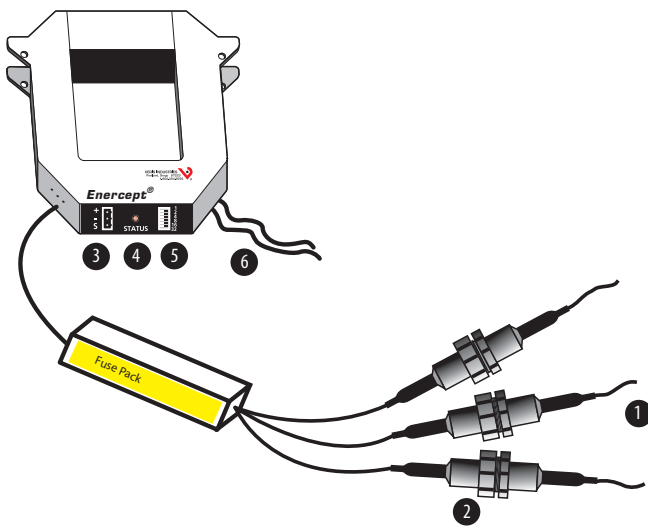

1. **Voltage Leads:** Input range is 208 to 480V.
2. **Fuses:** Maximum current draw 60mA. Fuses provided by the factory are rated ½A, 600VAC, 200 KAIC. Replace only with fuses of the same type and rating.
3. **Pulse Output connector**
4. **Status LED:** Blink codes: slow green for normal operation; slow red for incorrect wiring or low power factor (less than 0.5); fast red for maximum current exceedance.
5. **Pulse Rate Switches:** Used to set the pulse output rate.
6. **External CTs:** Permanently attached; do not disconnect or use with other power meters.



Color match CTs and voltage leads! Example: clamp the red labeled CT around the power conductor connected to the red voltage wire.

INSTALLATION



Connecting H8000 Series meters to the load side of a variable frequency drive will permanently damage the electronics. Connect only to the line side of a VFD.



Disconnect and lock out power before installation.

ADDRESS

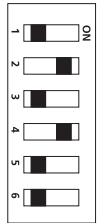

1. Choose a unique address and set the switches for that address as shown in the Address Selection Switches section. Only addresses 1 to 63 can be used.
2. Connect the voltage leads to the phase conductors, at a location that is not normally turned off. Connect voltage leads on the Line side of the conductor to ensure constant power to the meter. For a 3-phase system, connect the red lead to phase A, black to phase B, and yellow to phase C. See the Wiring section on the following page.
3. Snap the CT onto the conductor. Connect CTs to the correspondingly colored voltage lead. If the application can exceed 20 times the rated CT current, use wire ties to secure the I-bar to the CT housing. This CT automatically detects phase reversal, so CT load orientation is not important.
4. Remove the terminal block and attach the RS-485 wires. Observe (+), (-), and Shield polarity. Insulate any exposed wiring.

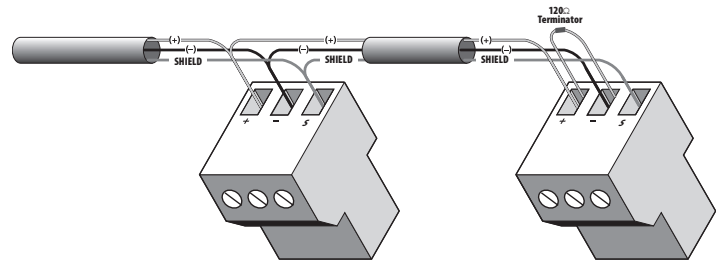
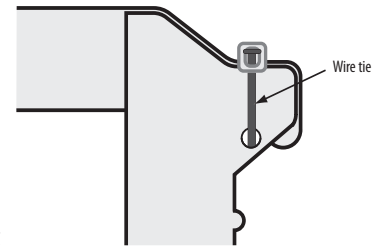

5. For information regarding software setup, see the Modbus protocol specifications available at www.veris.com/Modbus/.
6. Check power reading (these calculations are approximations only).

Expected power:
 kW = Volts x Amps x 1.732 x PF / 1000
 kW = Horsepower x 0.746

WIRING

Typical 208/480 VAC 3Ø, 3- or 4- Wire Installation

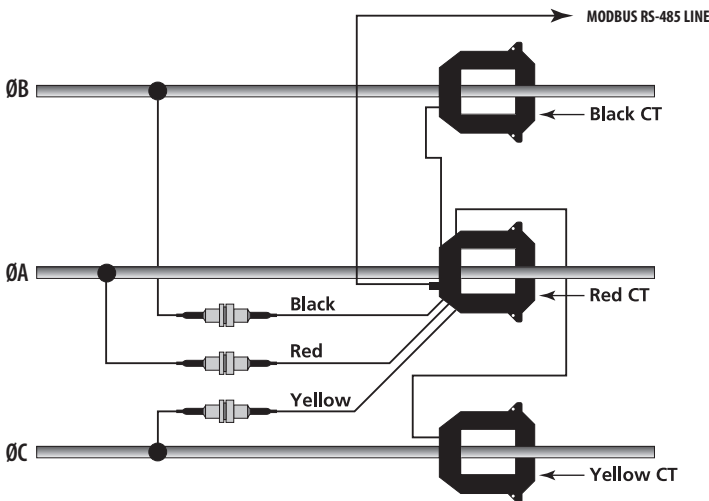

Typical 240/120 VAC 1Ø, 3-Wire Installation

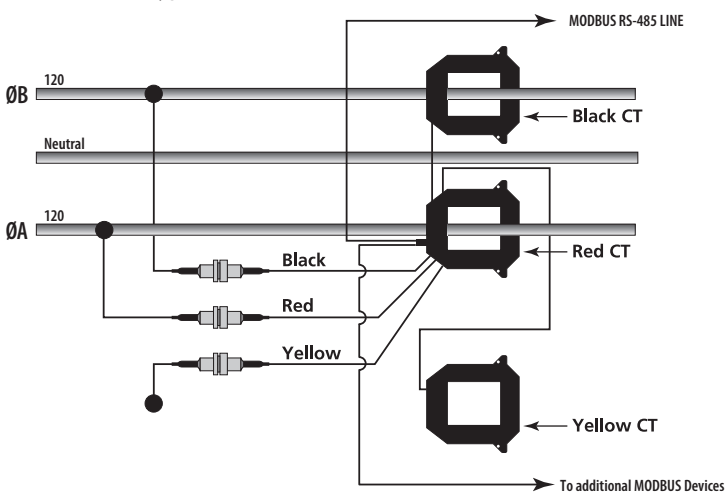

Typical 277 VAC 1Ø, 2-Wire Installation

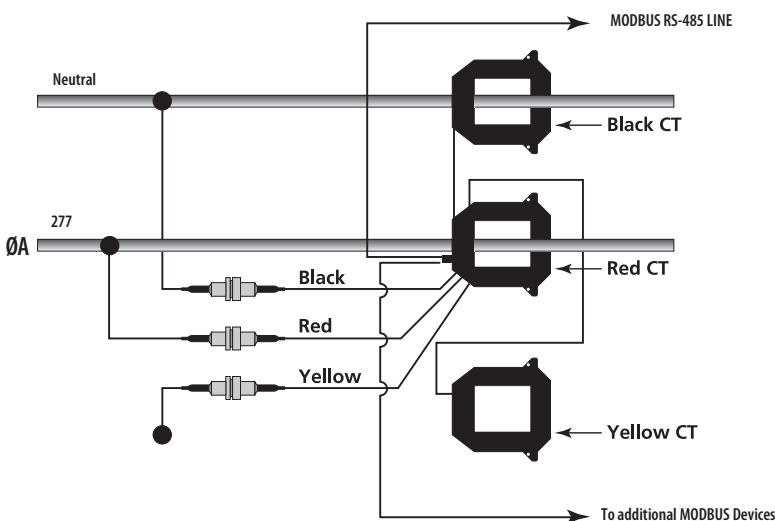

NOTES

1. DO NOT GROUND THE SHIELD INSIDE THE ELECTRICAL PANEL. All Modbus wires, including the shield, should be insulated to prevent accidental contact with high voltage conductors.
2. The Modbus cable should be mechanically secured where it enters the electrical panel.
3. All Modbus devices should be connected together in a daisy-chain fashion. The first and last devices in the chain should have a 120Ω terminating resistor between (+) and (-).
4. The Modbus cable should be shielded twisted pair wire BELDEN 1120A or similar.



WARNING: After wiring, remove all scraps of wire or foil shield from the electrical panel. This could be DANGEROUS if wire scraps come into contact with high voltage wires!

OUTPUT

H8035

kWh, consumption
Reset kWh
kW, demand

H8036

kWh, consumption
kW, demand
VAR, reactive power
VA, apparent power
Power factor
Average demand
Minimum demand
Maximum demand
Voltage, line-to-line
Voltage, line-to-neutral
Amps, average current
kW, demand ØA
kW, demand ØB
kW, demand ØC
Power factor ØA
Power factor ØB
Power factor ØC
Voltage, ØA to ØB
Voltage, ØB to ØC
Voltage, ØA to ØC
Voltage, ØA to Neutral
Voltage, ØB to Neutral
Voltage, ØC to Neutral
Amps, Current ØA
Amps, Current ØB
Amps, Current ØC

Note: The meter cannot communicate on the network bus without power. Therefore, it is best to connect the voltage leads ahead of switching devices.

ADDRESS SELECTION SWITCHES

Each Modbus device must have a unique address. These switches must be set to assign a unique address before the device is connected to the Modbus RS-485 line. If an address is selected which conflicts with another device, both devices will be unable to communicate.

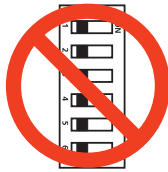

DO NOT USE ZERO!

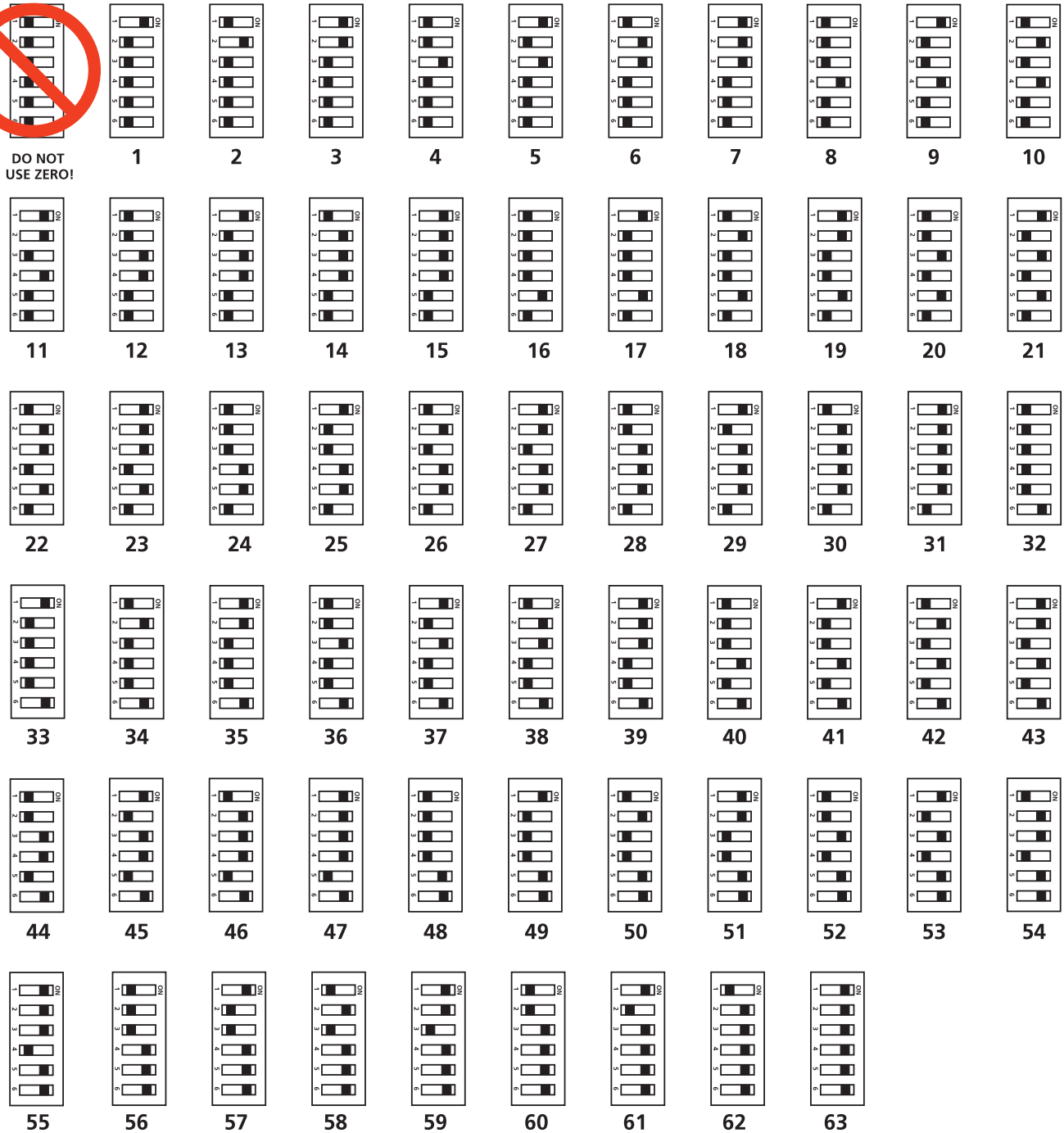

MODBUS REGISTER ADDRESSING

This table lists the addresses assigned to each data point. Registers are read Most Significant Byte (MSB) first. 32 bit floating point values are encoded per IEEE Standard 754. For floating point format variables, each data point appears twice because two 16-bit addresses are required to hold a 32-bit float value. The 16 bit Most Significant Word (MSW) is in the lower address of the register pair, while the least Significant Word (LSW) is in the upper address.

Modbus RTU function codes supported: 3=read holding registers; 6=preset single register; 17=report Slave I.D.

Quick Reference of the Most Common Data Points

Modbus Addr	Typical Offset	Units	Description	INTEGER: multiplier required	FLOAT: UPPER 16 bits	FLOAT: LOWER 16 bits
40001	0	KWH	Energy Consumption, LSW	X		
40002	1	KWH	Energy Consumption, MSW	X		
40003	2	KW	Demand (power)	X		
40257	---	KWH	Energy Consumption		X	
40258		KWH	Energy Consumption			X
40259	0	KWH	Energy Consumption (same 40257)		X	
40260		KWH	Energy Consumption (same 40258)			X
40261	2	KW	Demand (power)		X	
40262		KW	Demand (power)			X

Complete Listing of Data Points

Modbus Addr	Typical Offset	Units	Description	INTEGER: multiplier required	FLOAT: UPPER 16 bits	FLOAT: LOWER 16 bits
40001	0	KWH	Energy Consumption, LSW	X		
40002	1	KWH	Energy Consumption, MSW	X		
40003	2	KW	Demand (power)	X		
40004	3	VAR	Reactive Power	X		
40005	4	VA	Apparent Power	X		
40006	5	---	Power Factor	X		
40007	6	VOLTS	Voltage, line to line	X		
40008	7	VOLTS	Voltage, line to neutral	X		
40009	8	AMPS	Current	X		
40010	9	KW	Demand (power), phase A	X		
40011	10	KW	Demand (power), phase B	X		
40012	11	KW	Demand (power), phase C	X		
40013	12	---	Power Factor, phase A	X		

Complete Listing of Data Points, cont.

Modbus Addr	Typical Offset	Units	Description	INTEGER: multiplier required	FLOAT: UPPER 16 bits	FLOAT: LOWER 16 bits
40014	13	---	Power Factor, phase B	X		
40015	14	---	Power Factor, phase C	X		
40016	15	VOLTS	Voltage, phase A-B	X		
40017	16	VOLTS	Voltage, phase B-C	X		
40018	17	VOLTS	Voltage, phase A-C	X		
40019	18	VOLTS	Voltage, phase A-N	X		
40020	19	VOLTS	Voltage, phase B-N	X		
40021	20	VOLTS	Voltage, phase C-N	X		
40022	21	AMPS	Current, phase A	X		
40023	22	AMPS	Current, phase B	X		
40024	23	AMPS	Current, phase C	X		
40025	24	KW	Average Demand	X		
40026	25	KW	Minimum Demand	X		
40027	26	KW	Maximum Demand	X		
40257	---	KWH	Energy Consumption		X	
40258		KWH	Energy Consumption			X
40259	0	KWH	Energy Consumption (same 40257)		X	
40260		KWH	Energy Consumption (same 40258)			X
40261	2	KW	Demand (power)		X	
40262		KW	Demand (power)			X
40263	4	VAR	Reactive Power		X	
40264		VAR	Reactive Power			X
40265	6	VA	Apparent Power		X	
40266		VA	Apparent Power			X
40267	8	---	Power Factor		X	
40268		---	Power Factor			X
40269	10	VOLTS	Voltage, line to line		X	
40270		VOLTS	Voltage, line to line			X
40271	12	VOLTS	Voltage, line to neutral		X	
40272		VOLTS	Voltage, line to neutral			X
40273	14	AMPS	Current		X	
40274		AMPS	Current			X
40275	16	KW	Demand (power), phase A		X	
40276		KW	Demand (power), phase A			X
40277	18	KW	Demand (power), phase B		X	
40278		KW	Demand (power), phase B			X

Complete Listing of Data Points

Modbus Addr	Typical Offset	Units	Description	INTEGER: multiplier required	FLOAT: UPPER 16 bits	FLOAT: LOWER 16 bits
40279	20	KW	Demand (power), phase C		X	
40280		KW	Demand (power), phase C			X
40281	22	---	Power Factor, phase A		X	
40282		---	Power Factor, phase A			X
40283	24	---	Power Factor, phase B		X	
40284		---	Power Factor, phase B			X
40285	26	---	Power Factor, phase C		X	
40286		---	Power Factor, phase C			X
40287	28	VOLTS	Voltage, phase A-B		X	
40288		VOLTS	Voltage, phase A-B			X
40289	30	VOLTS	Voltage, phase B-C		X	
40290		VOLTS	Voltage, phase B-C			X
40291	32	VOLTS	Voltage, phase A-C		X	
40292		VOLTS	Voltage, phase A-C			X
40293	34	VOLTS	Voltage, phase A-N		X	
40294		VOLTS	Voltage, phase A-N			X
40295	36	VOLTS	Voltage, phase B-N		X	
40296		VOLTS	Voltage, phase B-N			X
40297	38	VOLTS	Voltage, phase C-N		X	
40298		VOLTS	Voltage, phase C-N			X
40299	40	AMPS	Current, phase A		X	
40300		AMPS	Current, phase A			X
40301	42	AMPS	Current, phase B		X	
40302		AMPS	Current, phase B			X
40303	44	AMPS	Current, phase C		X	
40304		AMPS	Current, phase C			X
40305	46	KW	Average Demand		X	
40306		KW	Average Demand			X
40307	48	KW	Minimum Demand		X	
40308		KW	Minimum Demand			X
40309	50	KW	Maximum Demand		X	
40310		KW	Maximum Demand			X

Note: Modbus addresses in the 4xxx format follow the Modicon protocol specification for point addressing. The actual address sent is the value shown, minus 40001. In other words, the leading "4" is omitted, and the remaining 4-digit number is decremented so that point 40001 is requested with a value of zero in the actual Modbus communication. Some Modbus implementations require point addresses to be specified beginning at zero or 40000, instead of 40001. Programing code may also require addresses which correspond to actual values transmitted, so a value of zero is used to request data beginning at modbus address 40001.

In many applications, a single Modbus command is used to read all of the data available from the meter. For integers, the beginning address is 40001 (or zero in the

actual Modbus command), and for floats the first address used would typically be 40259 (or 258 in the actual Modbus command). Although the first float appears at address 40257, it is not necessary to read this value because it is a duplicate copy of the kWh value (required by the product firmware). When a block of data is read, the "typical offset" values index to the data within the block.

"Multiplier required" indicates that a multiplication is required to properly scale the integer value. See Using Integer Data Types section.

USING INTEGER DATA TYPES

Unlike the floating-point data type, the integer data type can only represent whole numbers between zero and 65535. To convert a data point value into the number it represents, the value must be multiplied by a constant, as indicated in the table below.

Please note: some data points require different multipliers for each amperage range, while others, e.g. volts and power factor, use the same multiplier regardless of the amperage range of the product. The latter are indicated by single row values.

Addr	Units	100A	300/400A	800A	1600A	2400A
40001	kWh	7.81E-03	0.03125	0.0625	0.125	0.25
40002	kWh	512	2048	4096	8192	16384
40003	kW	0.004	0.016	0.032	0.064	0.128
40004	VAR	0.004	0.016	0.032	0.064	0.128
40005	VAR	0.004	0.016	0.032	0.064	0.128
40006	---	3.0518E-5				
40007	VOLTS	0.03125				
40008	VOLTS	0.015625				
40009	AMPS	3.906E-03	0.015625	0.03125	0.0625	0.1250
40010	kW	0.001	0.004	0.008	0.016	0.032
40011	kW	0.001	0.004	0.008	0.016	0.032
40012	kW	0.001	0.004	0.008	0.016	0.032
40013	---	3.0518E-5				
40014	---	3.0518E-5				
40015	---	3.0518E-5				
40016	VOLTS	0.03125				
40017	VOLTS	0.03125				
40018	VOLTS	0.03125				
40019	VOLTS	0.015625				
40020	VOLTS	0.015625				
40021	VOLTS	0.015625				
40022	AMPS	3.906E-03	0.015625	0.03125	0.0625	0.1250
40023	AMPS	3.906E-03	0.015625	0.03125	0.0625	0.1250
40024	AMPS	3.906E-03	0.015625	0.03125	0.0625	0.1250
40025	kW	0.004	0.016	0.032	0.064	0.128
40026	kW	0.004	0.016	0.032	0.064	0.128
40027	kW	0.004	0.016	0.032	0.064	0.128

As an alternative to the table on the previous page, it can be convenient to invert the values for use as divisors, where the integer value returned by the meter is divided by a number from the table below. In most cases, the divisors are a more compact number.

Addr	Units	100A	300/400A	800A	1600A	2400A
40001	kWh	128	32	16	8	4
40002	kWh	1.9531E-3	4.8828E-4	2.4414E-4	1.2207E-4	6.1035E-5
40003	kW	250	62.5	31.25	15.625	7.8125
40004	VAR	250	62.5	31.25	15.625	7.8125
40005	VA	250	62.5	31.25	15.625	7.8125
40006	---	32768				
40007	VOLTS	32				
40008	VOLTS	64				
40009	AMPS	256	64	32	16	8
40010	kW	1000	250	125	62.5	31.25
40011	kW	1000	250	125	62.5	31.25
40012	kW	1000	250	125	62.5	31.25
40013	---	32768				
40014	---	32768				
40015	---	32768				
40016	VOLTS	32				
40017	VOLTS	32				
40018	VOLTS	32				
40019	VOLTS	64				
40020	VOLTS	64				
40021	VOLTS	64				
40022	AMPS	256	64	32	16	8
40023	AMPS	256	64	32	16	8
40024	AMPS	256	64	32	16	8
40025	kW	250	62.5	31.25	15.625	7.8125
40026	kW	250	62.5	31.25	15.625	7.8125
40027	kW	250	62.5	31.25	15.625	7.8125

TROUBLESHOOTING

Problem	Solution
Status LED does not blink	Check fuses and voltage connections. Status LED should blink regardless of CTs, Modbus connections, and DIP switch setting.
Power meter interferes with another device on the Modbus	Set DIP switches to a different Modbus address not in use.
Readings seem highly inaccurate.	<ul style="list-style-type: none"> • Check that each CT is installed on the conductor with the corresponding color voltage input lead attached. In most cases, incorrect wiring will cause the STATUS LED to blink RED (slowly). However, a power factor lower than 0.5 could cause the LED to blink this way, even if the unit is installed properly. • It does not matter which side of the CT faces towards the load. • If current is below 7% of full scale maximum for the CT, use a smaller CT or wrap each wire through the CT multiple times • Check current with an amp-clamp. Expected power: kW = Volts x Amps x 1.732 x PF / 1000 kW = Horsepower x 0.746 PF is usually 0.7 to 0.95, depending on the load.
Meter goes offline when load is switched off.	Voltage leads must be connected on the Line side of the conductor. The power meter cannot communicate on the Modbus without voltage.
Status LED blinks red.	<ul style="list-style-type: none"> • If the LED blinks quickly (i.e., about 5 blinks in two seconds), then the use a CT with a higher amp rating. • If the LED blinks slowly (i.e., about 1 blink in two seconds) the CTs are not installed on the correct conductors, or the power factor is less than 0.5. The meter can accurately measure these low PFs, but few loads operate normally at such a low power factor.