

Obvius A8923-4 Installation Instructions



IO Module: Analog 4-20mA/0-10V and Pulse to Modbus

WARNING--REFER INSTALLATION AND SERVICING TO QUALIFIED PERSONNEL ONLY!

- Read instructions thoroughly prior to install
- This product is not intended for life or safety applications

Applications shown are suggested means of installing this product, but it is the responsibility of the installer to ensure that the installation is in compliance with all national and local codes. Installation should be attempted only by individuals familiar with proper installation techniques and with codes, standards, and proper safety procedures for control installations.

Installation, Wiring and Setup

1. Snap unit to existing DIN rail or use DIN rail provided.
2. Connect power supply, network wiring, and sensor inputs as indicated in wiring diagram.
3. Select network address as indicated by the diagram. Each modbus device must have a unique address.
4. Auto-detect analog inputs: Make sure all analog devices are properly installed and powered. Press the "LEARN" button. Inputs will automatically be identified as 4-20mA or 0-10V.
5. Verify pulse inputs: Contact closure on pulse inputs will cause red pulse LEDs to blink. Verify each pulse input is functioning properly.

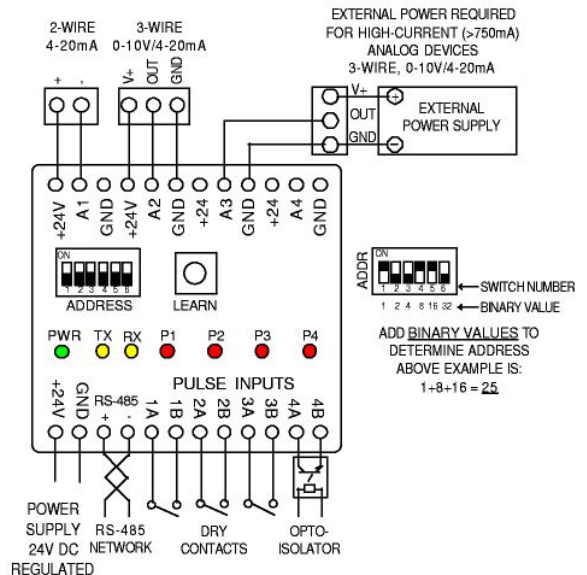

Modbus Point Map

Address	Function	Range	Address	Function	Range
40001	Analog 1 Instantaneous reading.	0-4095	40017	Pulse State Register	*See Note.
40002	Analog 2 Instantaneous reading.	0-4095	40018	Pulse 1 ontime LSW (seconds)	
40003	Analog 3 Instantaneous reading.	0-4095	40019	Pulse 1 ontime MSW (seconds)	
40004	Analog 4 Instantaneous reading.	0-4095	40020	Pulse 2 ontime LSW (seconds)	
40005	Pulse 1 LSW		40021	Pulse 2 ontime MSW (seconds)	
40006	Pulse 1 MSW		40022	Pulse 3 ontime LSW (seconds)	
40007	Pulse 2 LSW		40023	Pulse 3 ontime MSW (seconds)	
40008	Pulse 2 MSW		40024	Pulse 4 ontime LSW (seconds)	
40009	Pulse 3 LSW		40025	Pulse 4 ontime MSW (seconds)	
40010	Pulse 3 MSW		40026	Analog 1 min	0-4095
40011	Pulse 4 LSW		40027	Analog 1 average	0-4095
40012	Pulse 4 MSW		40028	Analog 1 max	0-4095
40013	Status Register	*See Note.	40029	Analog 2 min	0-4095
40014	Firmware Version (111 = 1.11)		40030	Analog 2 average	0-4095
40015	Uptime Seconds LSW (seconds)		40031	Analog 2 max	0-4095
40016	Uptime Seconds MSW (seconds)		40032	Analog 3 min	0-4095
			40033	Analog 3 average	0-4095
			40034	Analog 3 max	0-4095
			40035	Analog 4 min	0-4095
			40036	Analog 4 average	0-4095
			40037	Analog 4 max	0-4095

Supported Modbus commands:

0x03 Read Holding Registers
0x06 Preset Single Register
0x11 Report Slave ID

All other Modbus commands return "Illegal Function". The Status Register is the only register that is read/write.

Device ID = 50

Device name = "Obvius 4A4P-M2"

* Status Register (40013)

Bits 0-3 Analog input type. bit 0 is Analog 1
0=4-20mA, 1=0-10V (read/write)

Bits 4-7 Analog overcurrent/voltage. bit 4 is Analog 1
0=Ok, 1=Alarm (read-only)

Bits 8-11 Analog broken 4-20mA wire. bit 8 is Analog 1
0=Ok, 1=Alarm (read-only)

Bit 12 Debounce feature slows down the pulse scan rate for mechanical relays
0=250Hz Max, 1=20Hz Max (read/write)

Bit 13 1 = resets min/max/average to current value (read/write)

Bit 14 bit is unused. Always 0

Bit 15 1 = set learn mode (read/write)

* Pulse State Register (40017)

Bit 0 Pulse 1 status
0 = contacts open, 1 = contacts closed

Bit 1 Pulse 2 status
0 = contacts open, 1 = contacts closed

Bit 2 Pulse 3 status
0 = contacts open, 1 = contacts closed

Bit 3 Pulse 4 status
0 = contacts open, 1 = contacts closed

bits 4-15 Unused

The Obvius A8923-4 ships from the Factory configured for 0-10V. Press the Learn button if 4-20mA products are used.

When changing a single bit in the status register: First read the register from the IO module, next, set or clear the bit as needed and then write the register value back to the IO module. Simply writing 0x20 to set the pulse input debounce feature will also force all analog inputs into 4-20mA mode.

Troubleshooting

Power LED is not on: Ensure 24VDC is present and polarity is correct.

Data LEDs do not blink: Check network wiring, address selection. Verify master Modbus controller is functioning.

Pulse LEDs do not blink: Verify pulse inputs are dry contact or opto-isolator wired with correct polarity.

Analog values inaccurate: Verify analog devices are wired correctly. Press LEARN button to re-configure.
Verify Modbus master is configured to scale sensor outputs properly.
Check sensor output range. Make sure Modbus master is configured with correct scaling.

No output from unit: Check network wiring, address selection. Verify Modbus master device is configured to read correct points.

Specification

Inputs

Power 24vdc, 50mA, + converter powered analog devices

Analog 4-20mA or 0-10v auto-detected (ranges and units set in master device)
0-10v Input impedance = 10k ohms
4-20mA Input Impedance = 250 ohms
Scan Rate 250mS (1/4 second)

Pulse Dry contact, 250Hz max. (user selectable to 20Hz max)
input impedance 500 ohms max.

Accuracy +/- 0.25% F.S. (Analog Input)

Output

Hardware RS-485, 2-wire, non-isolated

Protocol Modbus RTU Protocol, 9600baud

Latency 5mS

Configuration

Address 6-position DIP switch, 63 addresses

Analog Input Auto-detecting 0-10v or 4-20mA (ranges and units set in master device)

General

Dimensions 4-module, 70mm x 86mm x 58mm(h)

Material Base part: Black Noryl UL94-V0; PCB material: FR-4

Mounting M36 DIN-RAIL (EN50022)

Operating Environment 0 to 50 degrees C, 0 to 95%RH non-condensing

